

OPERATING VOLTAGE	2-WIRE AC/DC, 20-250 VAC/VDC
OUTPUT FUNCTION.....	CONNECTION PROGRAMMABLE
EMBEDDABLE	YES
RATED OPERATING DISTANCE.....	40 mm
APPROVAL OR CERTIFICATION.....	CSA (C US), CE
SHORT-CIRCUIT PROTECTION.....	NO
WELD-FIELD IMMUNITY.....	NO
SWITCHING FREQUENCY.....	20 Hz
LINE FREQUENCY.....	40-60 Hz
DIFFERENTIAL TRAVEL <HYSTERESIS>.....	3-15% (5% TYPICAL)
VOLTAGE DROP ACROSS CONDUCTING SENSOR.....	≤7.0 V AT 500 mA
CONTINUOUS LOAD CURRENT.....	≤500 mA
OFF-STATE <LEAKAGE> CURRENT.....	≤1.7 mA
MINIMUM LOAD CURRENT.....	≥5.0 mA
INRUSH CURRENT.....	≤8.0 A (≤10 ms, 5% DUTY CYCLE)
TIME DELAY BEFORE AVAILABILITY.....	≤80 ms
POWER-ON EFFECT.....	PER IEC 947-5-2
TRANSIENT PROTECTION.....	PER EN 60947-5-2
OPERATING TEMPERATURE.....	-25°C TO +70°C (-13°F TO + 158°F)
SHOCK.....	30 g, 11 ms
VIBRATION.....	55 Hz, 1 mm AMPLITUDE (ALL 3 PLANES)
REPEATABILITY.....	≤2% OF RATED OPERATING DISTANCE
NUMBER OF LEDS.....	2
LED FUNCTION <RED>.....	OUTPUT ENERGIZED
LED FUNCTION <GREEN>.....	POWER ON
ENCLOSURE.....	MEETS NEMA 1,3,4,6,13, AND IEC IP 67
CONNECTION.....	3-PIN microfast CONNECTOR
CONNECTOR MATERIAL.....	CHROME-PLATED BRASS
HOUSING MATERIAL.....	PBT-GF30-V0 PLASTIC
TERMINAL CHAMBER COVER MATERIAL.....	TROGAMID T

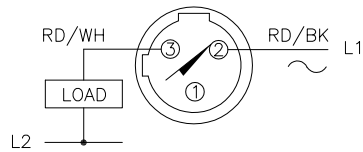
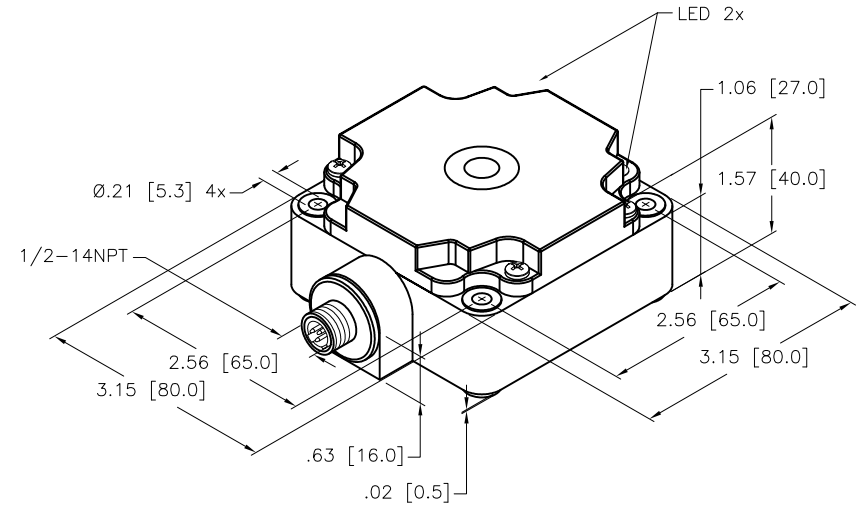

SOURCE DRAWING - FOR REFERENCE ONLY

CAUTION! NOT SHORT-CIRCUIT PROTECTED. AN ELECTRICAL SHOCK HAZARD EXISTS INSIDE OF TERMINAL CHAMBER-STYLE SENSORS WHENEVER POWER IS APPLIED. REMOVE ALL POWER TO THE SENSOR WHENEVER SENSOR WIRING IS EXPOSED.

NOTE: ALL DIMENSIONAL TOLERANCES ±1.0 mm.

RELATED DOCUMENTS 1. 2. 3. 4.	3RD ANGLE PROJECTION 	THIS DRAWING IS CONFIDENTIAL AND THE PROPERTY OF TURCK INC. USE OF THIS DOCUMENT WITHOUT WRITTEN PERMISSION IS PROHIBITED.		3000 CAMPUS DRIVE MINNEAPOLIS, MN 55441 1-800-544-7769 (763) 553-7300 (763) 553-0708 fax www.turck.us	
	MATERIAL	DRFT CBM	DATE 09/13/00	DESCRIPTION BI40-CP80-FZ3X2-B3131	
FINISH	ALL DIMENSIONS DISPLAYED ON THIS DRAWING ARE FOR REFERENCE ONLY	APVD	SCALE NONE	IDENTIFICATION NO. 1340491	
	CONTACT TURCK FOR MORE INFORMATION	UNIT OF MEASUREMENT INCH [MILLIMETER]		REV C	
C	UPDATE ID NUMBER PER HARMONIZATION PROJECT	CBM	11/06/17	DO NOT SCALE THIS DRAWING	
REV	DESCRIPTION	BY	DATE	ECO NO.	FILE: 1340491 SHEET 1 OF 1